



INSTALLATION AND MAINTENANCE INSTRUCTIONS

TARG AND TPRG SERIES UNITS

RESIDENTIAL PACKAGED UNITS

Air Conditioners and Heat Pumps

507296M04

11/2022

THIS MANUAL MUST BE LEFT WITH THE HOMEOWNER FOR FUTURE REFERENCE

Table of Contents

Unit Dimensions	2
Roof Curb Dimensions	4
Adjustable Roof Curb Dimensions.....	6
Installation	9
Electrical Wiring.....	11
Duct System	12
Filters.....	12
Condensate Drain.....	13
Sequence of Operation.....	14
Maintenance.....	19
Wiring Diagrams.....	21

WARNING

Installation and servicing of air conditioning equipment can be hazardous due to internal refrigerant pressure and live electrical components. Only trained and qualified service personnel should install or service this equipment. Installation and service performed by unqualified persons can result in property damage, personal injury, or death.

WARNING

Do not store combustible materials, including gasoline and other flammable vapors and liquids, near the unit, vent pipe, or warm air ducts. Such actions could cause property damage, personal injury, or death.

Comfort-Aire / Century
1900 Wellworth Ave.
Jackson, MI 49203



(P) 507296M04

CAUTION

The installation of this appliance must conform to the requirements of the National Fire Protection Association; the National Electrical Code, ANSI/NFPA No. 70 (latest edition) in the United States; the Canadian Electrical Code Part 1, CSA 22.1 (latest edition) in Canada; and any state or provincial laws or local ordinances. Local authorities having jurisdiction should be consulted before installation is made. Such applicable regulations or requirements take precedence over the general instructions in this manual.

Save these instructions for future reference

Unit Dimensions - Small Base Air Conditioners & Heat Pumps

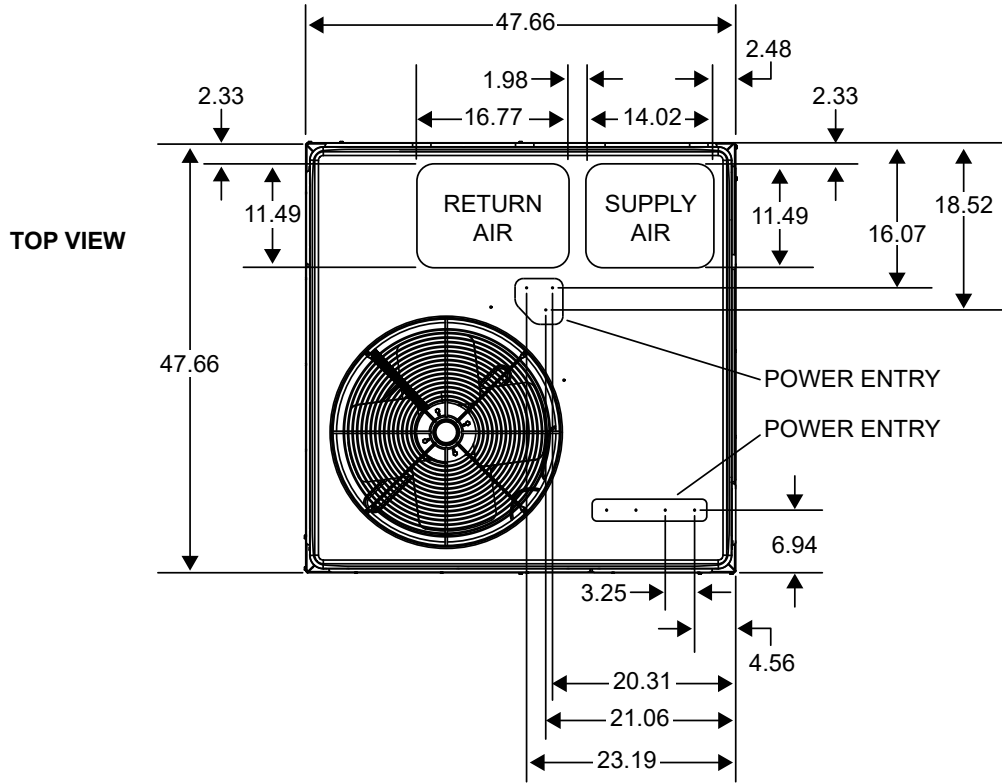

SIDE VIEWS

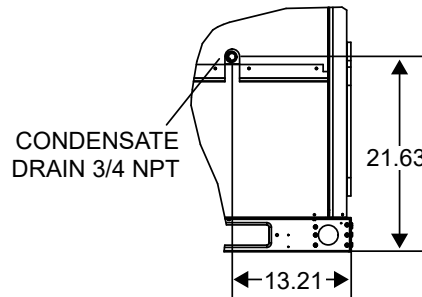
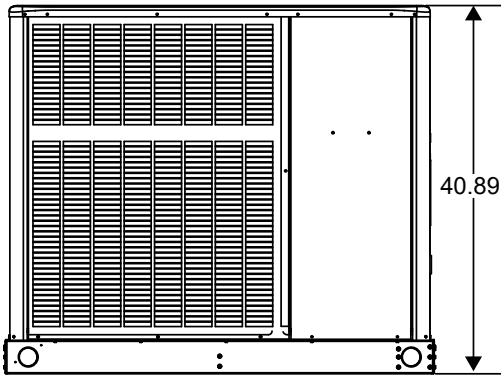

TYPICAL DRAIN LOCATION

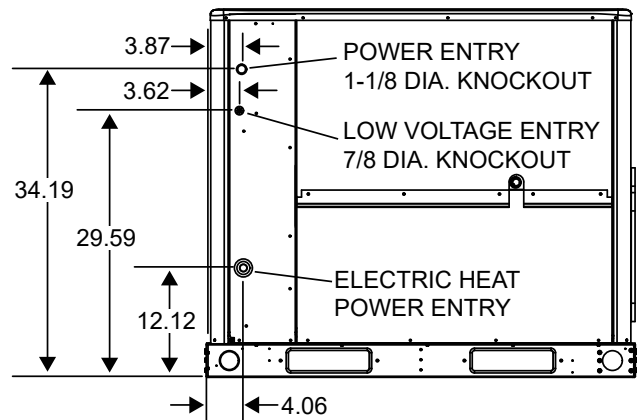
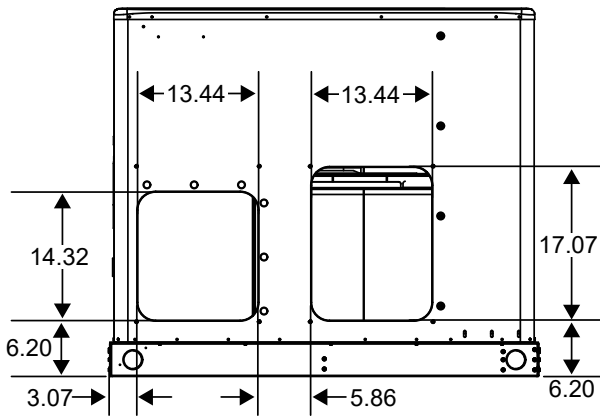

Unit Dimensions - Large Base Air Conditioners & Heat Pumps

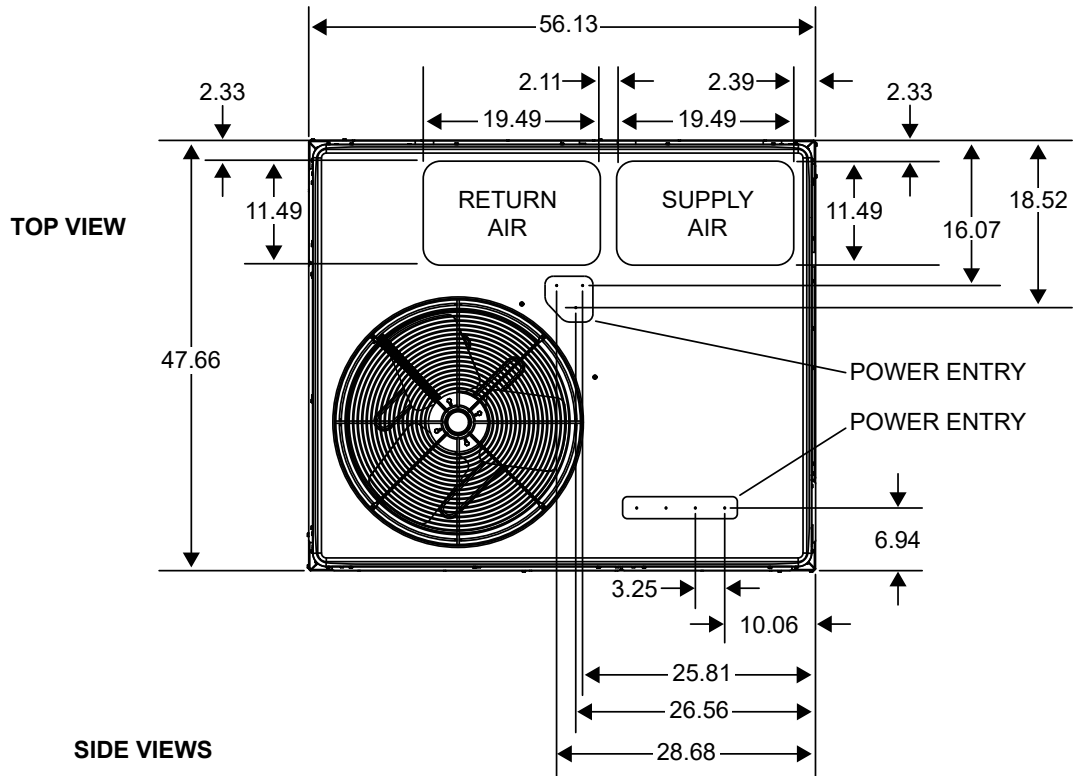

SIDE VIEWS

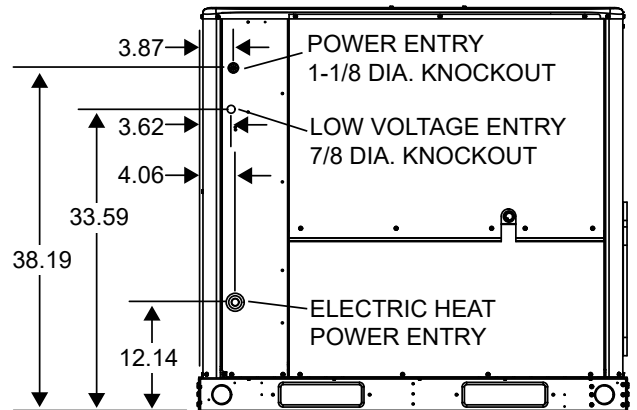
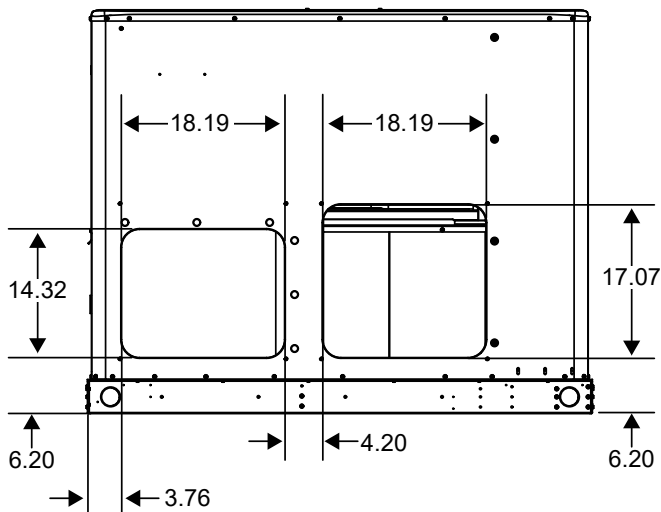
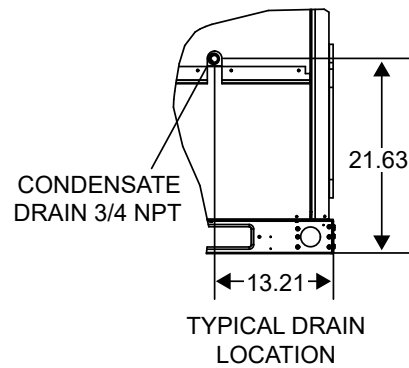
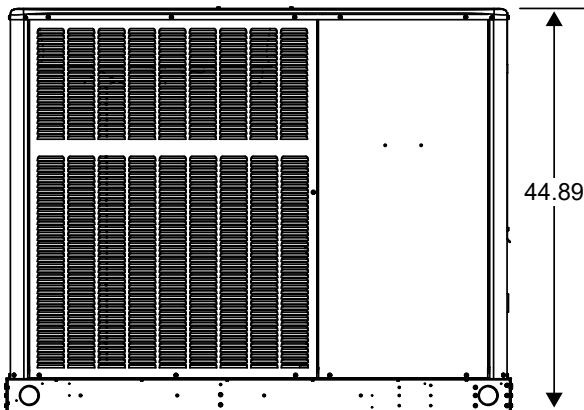

Roof Curb Dimensions - Small Base Air Conditioners & Heat Pumps

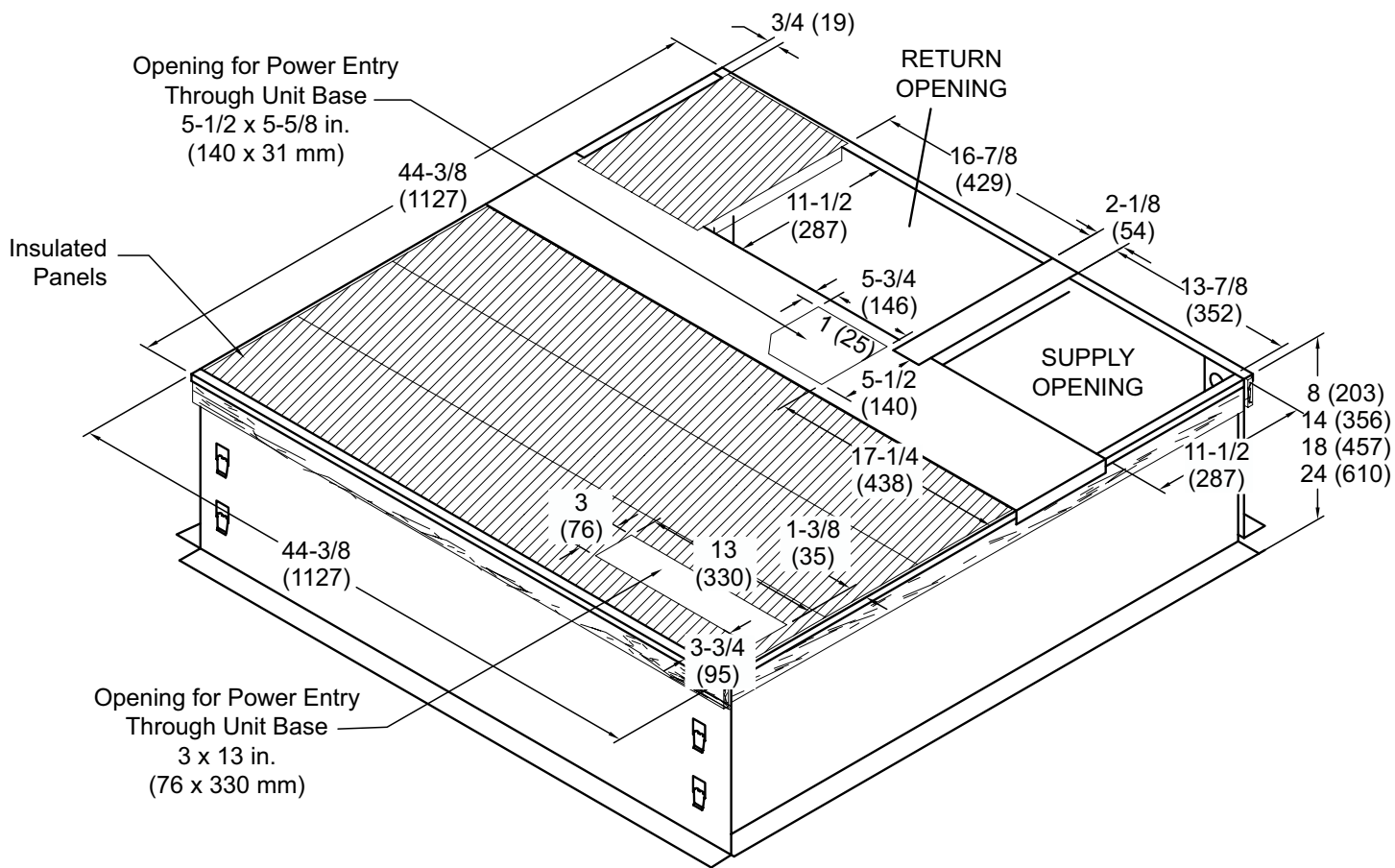

NOTE - Roof deck may be omitted within confines of curb.

Roof Curb Dimensions - Large Base Air Conditioners & Heat Pumps

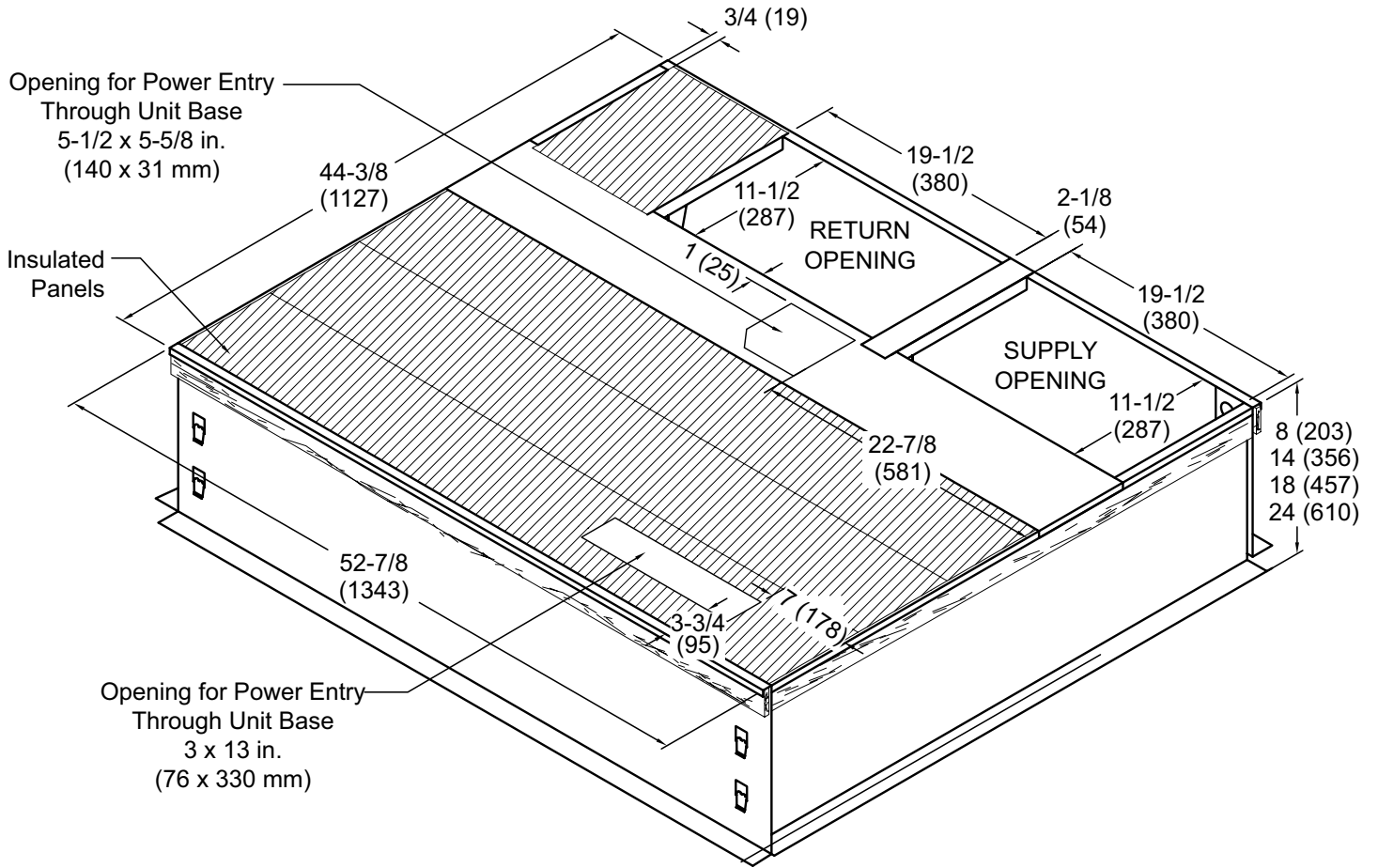

NOTE - Roof deck may be omitted within confines of curb.

Adjustable Roof Curb Dimensions - Small Base Air Conditioners & Heat Pumps (Knock-Down Style)

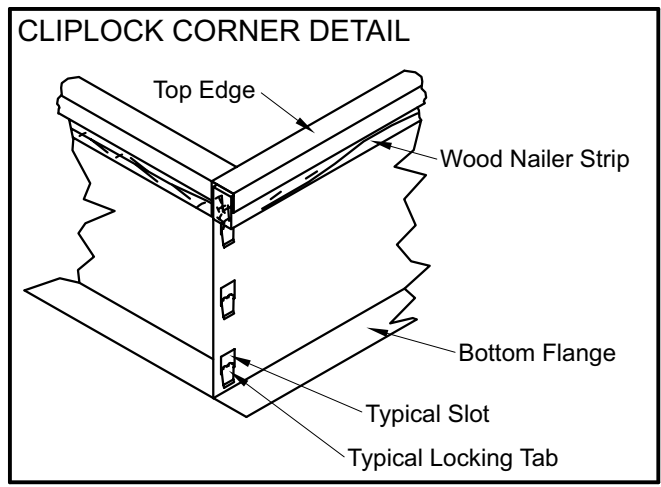

NOTE: See Cliplock 1000 installation instructions for complete assembly and installation procedures and requirements.

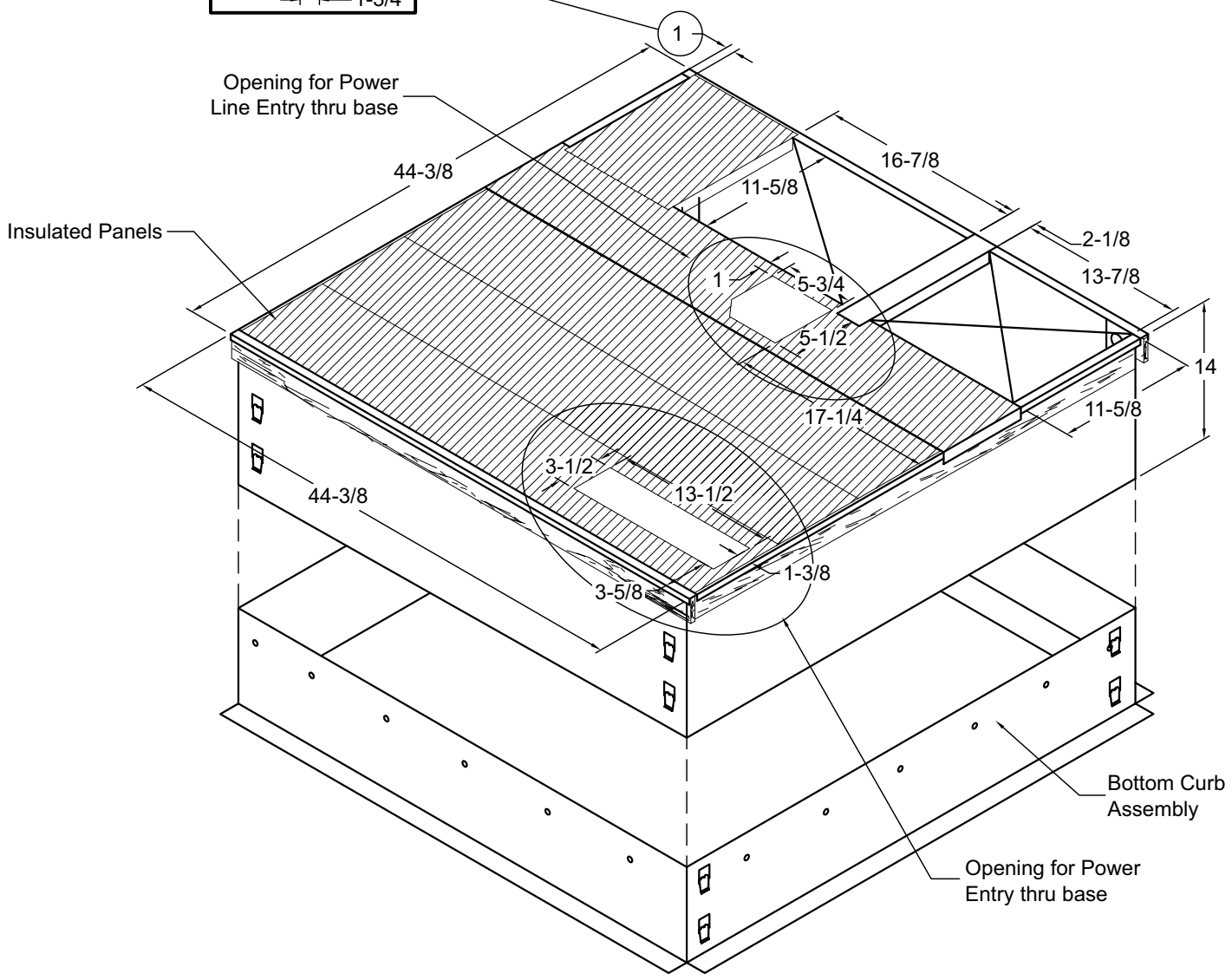
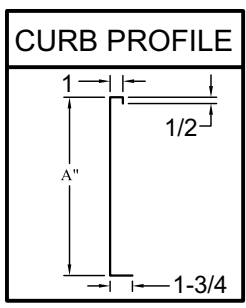

NOTE - Roof deck may be omitted within confines of curb.

Adjustable Roof Curb Dimensions - Large Base Air Conditioners & Heat Pumps (Knock-Down Style)

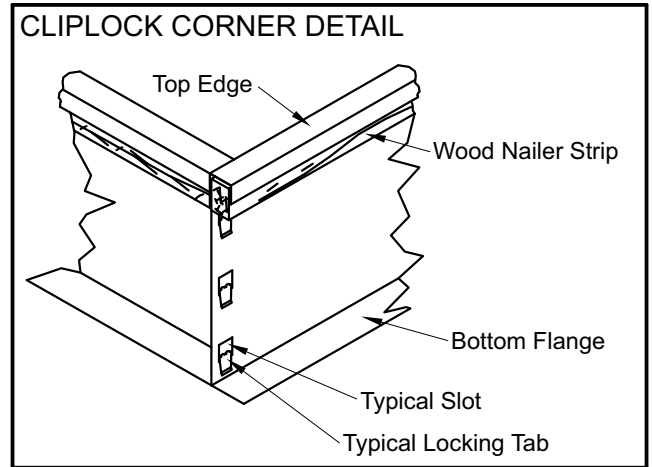

NOTE: See Cliplock 1000 installation instructions for complete assembly and installation procedures and requirements.

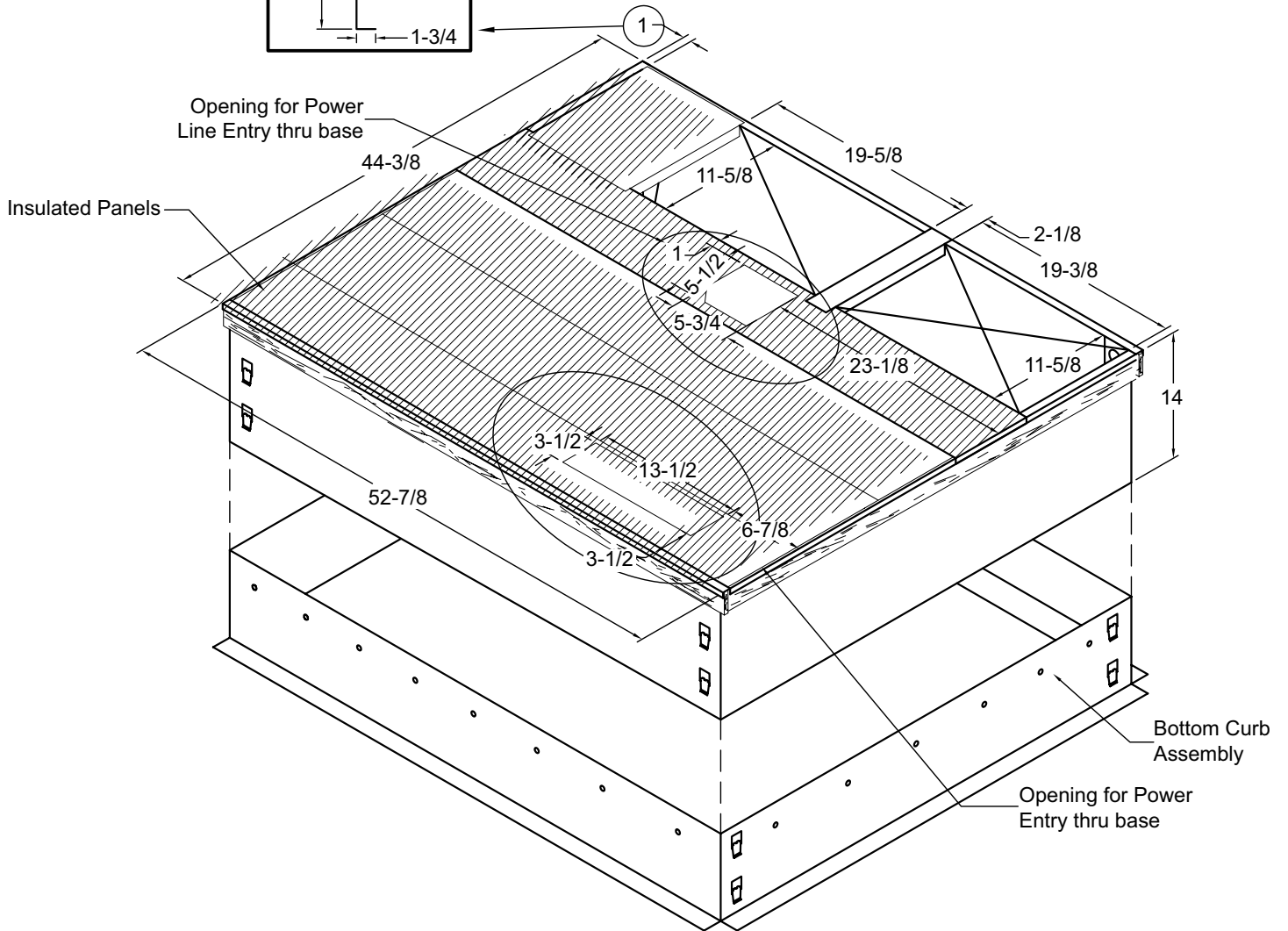
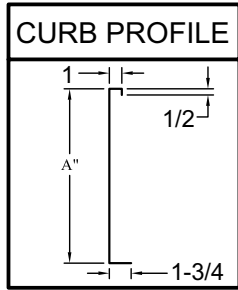

NOTE - Roof deck may be omitted within confines of curb.

Adjustable Roof Curb Dimensions - Air Conditioners & Heat Pumps (Welded Style)

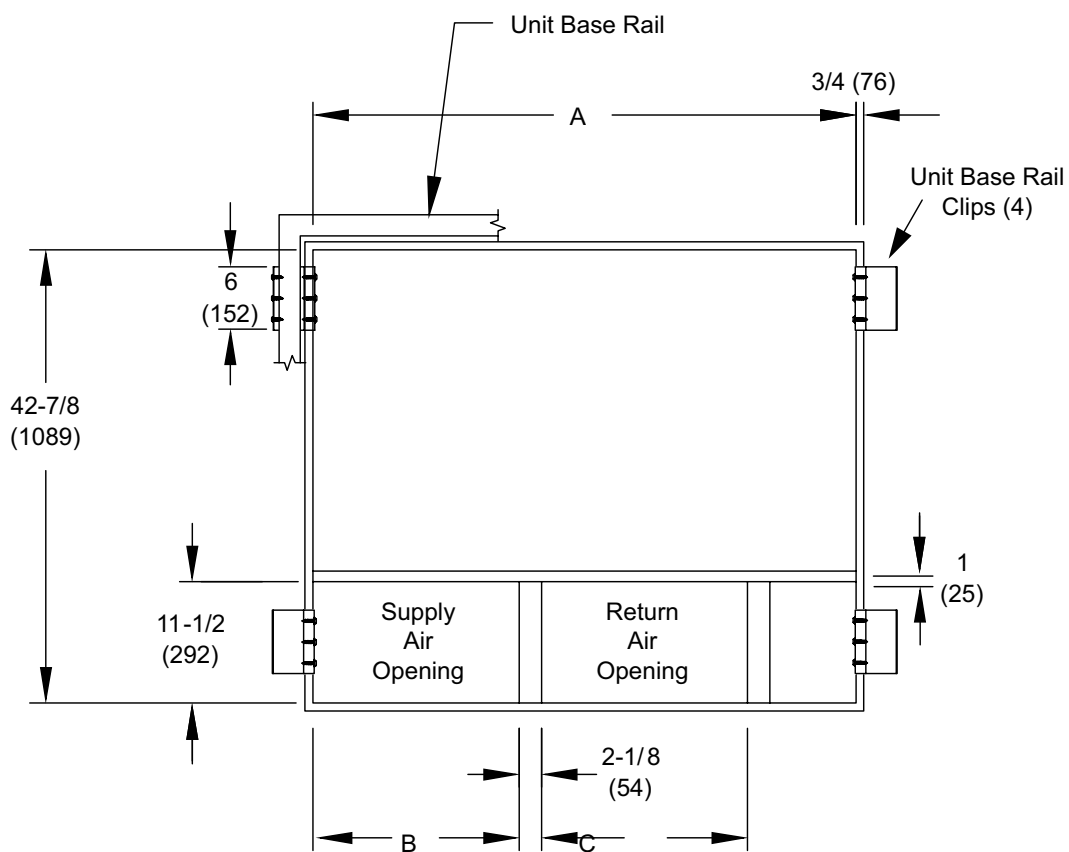
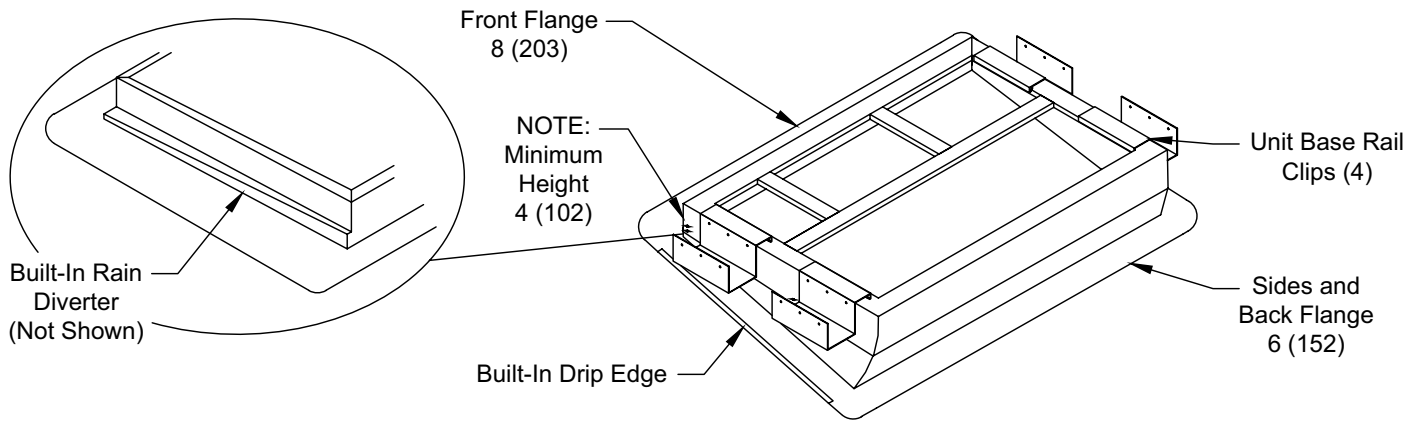

Usage	A		B		C	
	in.	mm	in.	mm	in.	mm
24,30,36	42-7/8	1089	13-7/8	352	16-7/8	429
42,48,60	51-3/8	1305	19-1/2	495	19-1/2	495

WARNING

Improper installation, adjustment, alteration, service, or maintenance can cause injury or property damage. Refer to this manual. For assistance or additional information, consult a qualified installer or service agency.

Installation

These instructions explain the recommended method of installation of the packaged heat pump and air conditioner units and associated electrical wiring.

This unit is designed and approved for use as a self-contained air-to-air outdoor heat pump and air conditioner system.

The units are factory-equipped with a transformer and blower control for applications without auxiliary heat. Electric heat accessory kits (PHK-) can be ordered for field installation of additional heat where required.

These instructions, and any instructions packaged with mating components and/or accessories, should be carefully read prior to beginning installation. Note particularly any **CAUTIONS** or **WARNINGS** in these instructions and all labels on the units.

These instructions are intended as a general guide only, for use by qualified personnel and do not supersede any national or local codes in any way. Compliance with all local, state, provincial, or national codes pertaining to this type of equipment should be determined prior to installation.

Inspection of Shipment

Upon receipt of equipment, carefully inspect it for possible shipping damage. If damage is found, it should be noted on the carrier's freight bill. Take special care to examine the unit inside the carton if the carton is damaged. File a claim with the transportation company.

If any damages are discovered and reported to the carrier, **DO NOT INSTALL THE UNIT, as claim may be denied.**

Check the unit rating plate to confirm specifications are as ordered.

Limitations

The unit should be installed in accordance with all national and local safety codes.

Limitations of the unit and appropriate accessories must also be observed.

The unit must not be installed with any ductwork in the outdoor air stream. The outdoor fan is not designed to operate against any additional static pressure.

Location

The unit is designed to be located outdoors with sufficient clearance for free entrance to the air inlet and discharge air openings. The location must also allow for adequate service access.

The unit must be installed on a solid foundation that will not settle or shift. Adequate structural support must be provided. Install the unit in level position. Isolate the base from the building structure to avoid possible transmission of sound or vibration into the conditioned space.

The heat pump unit foundation should be raised to a minimum of 3" above finish grade. In areas that have prolonged periods of temperature below freezing and snowfall, the heat pump unit should be elevated above the average snow line. Extra precaution should be taken to allow free drainage of condensate from defrost cycles to prevent ice accumulation. The unit should not be located near walkways to prevent possible icing of surface from defrost condensate.

Avoid placing the unit near quiet areas, such as sleeping quarters or study rooms. Normal operating sound levels may be objectionable if the unit is placed near certain rooms.

For improved start-up performance, the condenser coil should be washed with suitable detergent to remove any residue from manufacturing processes.

Use of Unit During Construction

Use of this unit as a construction heater or air conditioner is not recommended during any phase of construction. Very low return air temperatures, harmful vapors and operation of the unit with clogged or misplaced filters will damage the unit.

If this unit has been used for heating or cooling of buildings or structures under construction, the following conditions must be met or the warranty will be void:

- A room thermostat must control the unit. The use of fixed jumpers that will provide continuous heating or cooling is not allowed.
- A pre-filter must be installed at the entry to the return air duct.
- The return air duct must be provided and sealed to the unit.
- Return air temperature range between 55°F (13°C) and 80°F (27°C) must be maintained.
- Air filters must be replaced and pre-filters must be removed upon construction completion.
- The input rate and temperature rise must be set per the unit rating plate.
- The heat exchanger, components, duct system, air filters and evaporator coil must be thoroughly cleaned following final construction clean-up.

- The unit operating conditions (including airflow, cooling operation, ignition, input rate, temperature rise and venting) must be verified according to these installation instructions.

Clearances

All units require certain clearances for proper operation and service. Refer to Table 1 for the minimum clearances to combustibles required for construction, servicing, and proper unit operation.

In the U.S., units may be installed on combustible floors made from wood or class A, B, or C roof covering material.

In Canada, units may be installed on combustible floors. Units must be installed outdoors.

Do not permit overhanging structures or shrubs to obstruct condenser air discharge outlet.

	Clearance to Combustibles	Clearance for Service Access
Front of unit	0 in.	24 in.
Back of unit	0 in.	0 in.
Left side	0 in.	24 in.
Right side	0 in.	24 in.
Base of unit	0 in.	0 in.
Top of unit	0 in.	48 in.
For any future service, installer must provide access to screws of top and rear panels.		

Table 1. Minimum Clearances

Compressor

Units are shipped with compressor mountings factory adjusted and ready for operation. **Do not loosen compressor mounting bolts.**

Roof Curb Installation

If a roof curb is used, follow the manufacturer's installation instructions and be sure that all required clearances are observed (see Clearances section).

Prior to setting the unit on the roof curb, the shipping bracket located underneath the unit must be removed. Remove the two screws in the base rail (located on the front and rear sides of the unit). The four screws and the bracket can be discarded. See Figure 1.

Rigging Unit

Exercise care when moving the unit. Do not remove any packaging until the unit is near the place of installation.

1. Connect rigging to the unit base rails using both holes in each corner.
2. All panels must be in place for rigging.
3. Place field-provided spreaders in place. Spreaders must be of adequate strength and length (must exceed unit dimension by 6 inches).

Units may also be moved or lifted with a forklift. **The lengths of the forks of the forklift must be a minimum of 42 inches.**

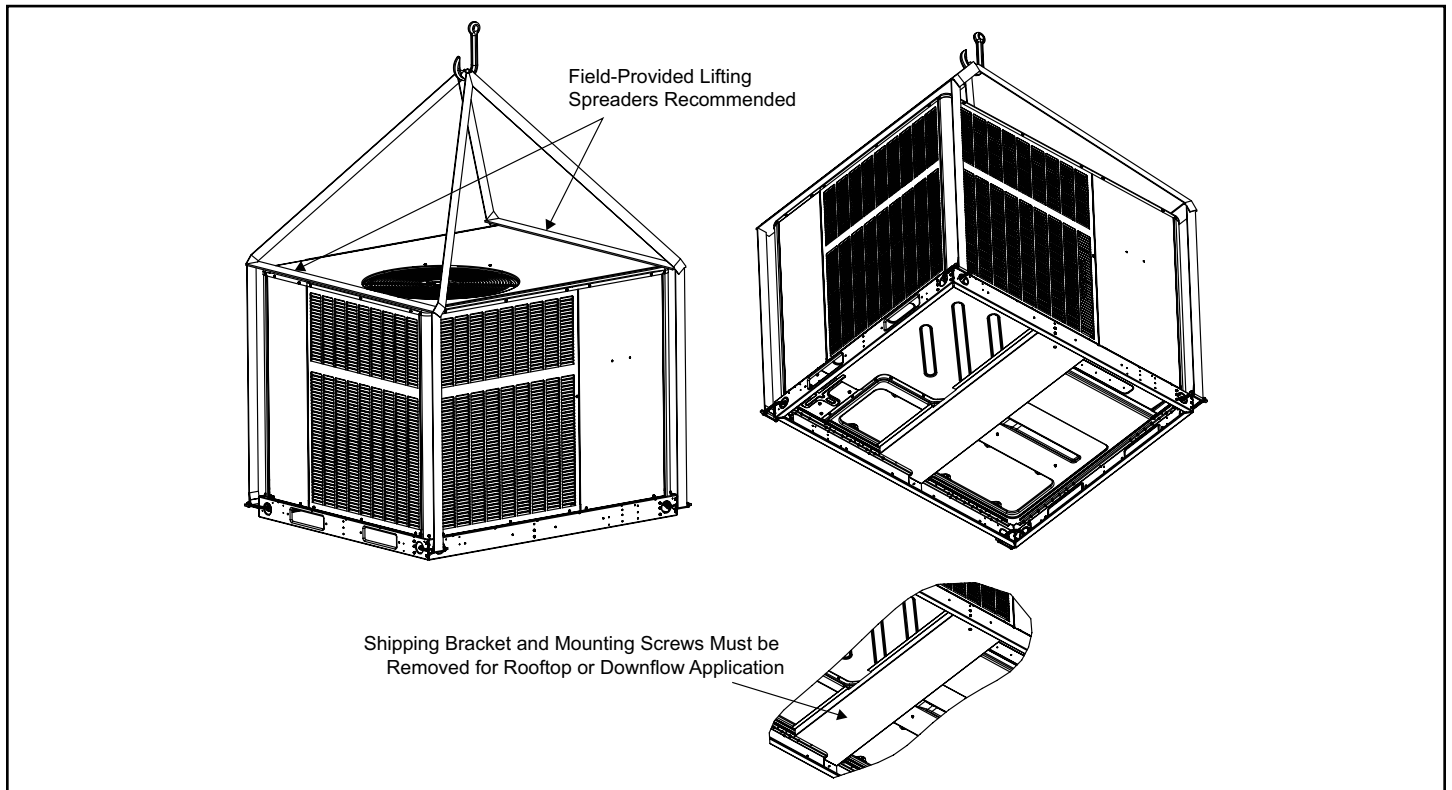

Figure 1.

CAUTION

Before lifting a unit, make sure that the weight is distributed equally on the cables so that it will lift evenly.

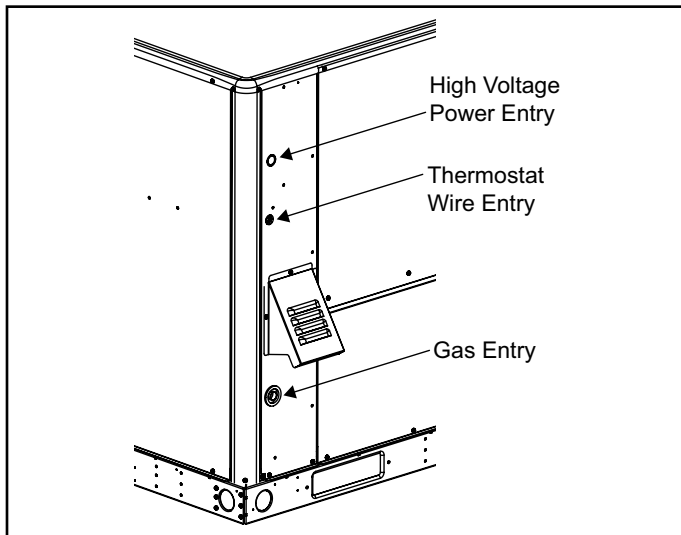

Figure 2.

Unpacking

Locate the four stacking brackets at each corner of the top panel. Remove the screws and washers that secure these brackets. All screws must be re-installed. The washers and stacking brackets can be discarded. Remove the bag and remaining packaging material, which can be discarded. Locate the four plastic fork slot bumpers on the base rails. Remove the fasteners and bumpers and discard.

CAUTION

As with any mechanical equipment, personal injury can result from contact with sharp sheet metal edges. Be careful when you handle this equipment.

Service Access

Access to all serviceable components is provided by four removable panels: upper access panel (for blower, ID coil, and optional filter), auxiliary heat access, control access panel, and compressor access.

WARNING

This unit is charged with HFC-410A refrigerant. Operating pressures for units charged with HFC-410A are higher than pressures in units charged with HCFC-22. All service equipment MUST be rated for use with HFC-410A refrigerant.

Electrical Wiring

All field wiring must be done in accordance with National Electrical Code recommendations, local codes, and applicable requirements of UL Standards, or in accordance with Canadian Electrical Code recommendations, local codes, or CSA Standards. Power wiring, disconnect means, and over-current protection are to be supplied by the installer. Refer to the unit rating plate for maximum over-current protection and minimum circuit ampacity, as well as operating voltage. The power supply must be sized and protected according to specifications supplied.

The unit must be grounded with a separate ground conductor. See Figure 4 for typical field wiring connection. The wiring diagram can be found on the unit inside the access panel. Low voltage control wiring are terminal strip or pigtail leads located on the main control box and are color-coded to match the connection called out on the wiring schematic.

NOTE: An optional bottom-entry power kit is available for these units. See the kit instructions for proper installation details.

CAUTION

When connecting electrical power and control wiring to the unit, waterproof-type connectors must be used so that water or moisture cannot be drawn into the unit during normal operation.

Units are factory wired for a 230-volt power supply. If power supply is 208 volts, it will be necessary to change a wire connection on the unit transformer from 240V terminal to 208V terminal as shown on the wiring diagram.

Use only copper conductors.

If any of the original unit wiring is replaced, the same size and type wire must be used.

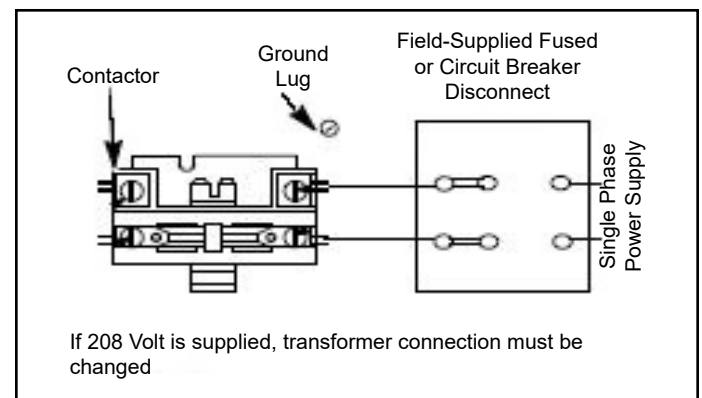

Figure 3. 208/230 Line Voltage Wiring

Thermostat

The room thermostat should be located on an inside wall where it will not be subject to drafts, sun exposure, or heat from electrical fixtures or appliances. Follow the manufacturer's instructions enclosed with the thermostat for general installation procedure. Color-coded insulated wires (#18 AWG) should be used to connect the thermostat to the unit. A minimum of five wires are required for proper installation.

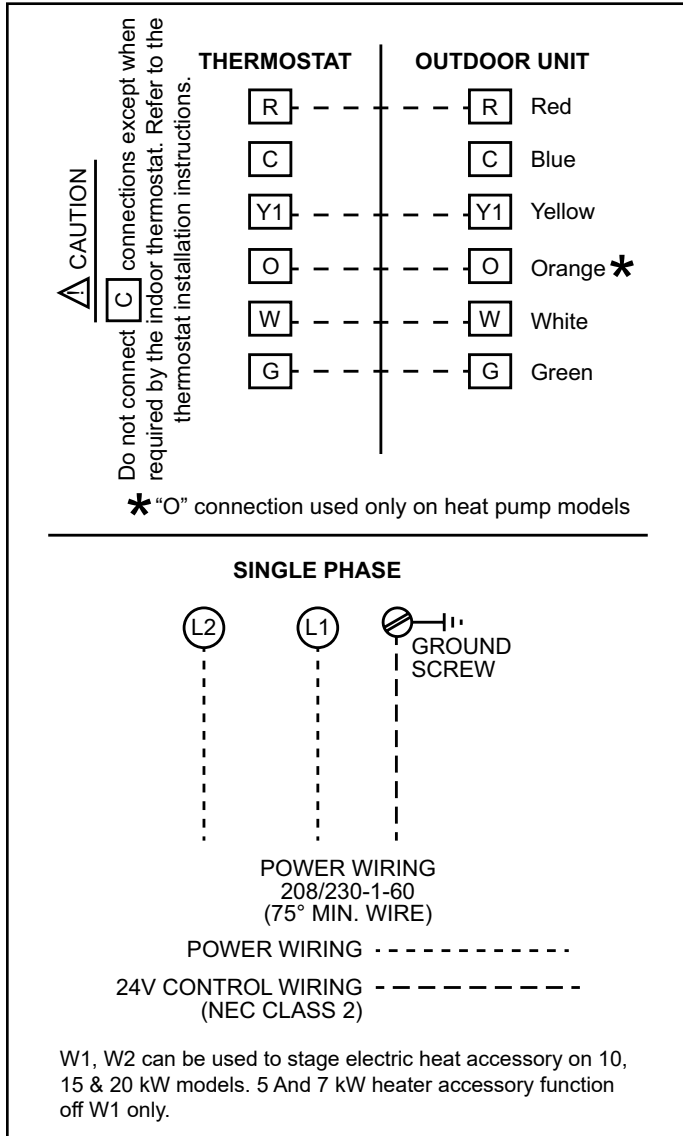

Figure 4. Typical Wiring Connections

Duct System

The duct system should be designed and sized according to the methods in the Air Conditioning Contractors of America (ACCA) manual that is most appropriate to the installation application.

A closed return duct system shall be used. This shall not preclude use of economizers or outdoor fresh air intake. It is recommended that supply and return duct connections at the unit be made with flexible joints.

The supply and return air duct systems should be designed for the CFM and static requirements of the job. **They should not be sized to match the dimensions of the duct connections on the unit.**

The unit is shipped ready for horizontal flow (side duct connections) or downflow (bottom duct connections). All units are equipped with a drain pan overflow switch that is installed and wired at the factory. Duct attachment screws are intended to go into the duct panel flanges. Duct to unit connections must be sealed and weather proofed.

For horizontal duct systems:

1. Remove the duct covers on side of the unit. They can be discarded.
2. Install the duct system to the unit.

For downflow duct systems:

1. Remove the duct covers on side of the unit. Keep the screws and the covers as they will be re-installed later.
2. Remove the downflow duct covers located inside unit. Remove the four screws securing each cover. Remove the covers from the unit. They can be discarded.
3. Remove screws located between the supply and return air openings that attach the blower deck to the base pan. These screws can interfere with bottom duct connections or roof curb seals. Discard these screws.
4. Install the duct system to the unit.
5. Re-install the duct covers removed in Step 1.

Filters

Air filters are not supplied with the unit. A field-provided air filter must always be installed ahead of the evaporator coil and must be kept clean or replaced. Dirty filters will reduce the airflow of the unit.

An optional filter rack kit may be purchased separately for installation inside the unit's coil compartment. Air filter sizes are shown in Table 2 for use with filter rack kit.

NOTE:

The filter rack must be installed prior to installation of the unit in applications where access to the rear panel is limited.

Unit Model	Filter 1	Filter 2
24,30,36	14 x 20 x 1	20 x 20 x 1
42,48,60	20 x 20 x 1	

Table 2. Unit Air Filter Sizes - inches

Condensate Drain

This package unit is equipped with a 3/4" FPT coupling for condensate line connection. Plumbing must conform to local codes. Use a sealing compound on male pipe threads.

Do not operate unit without a drain trap. The condensate drain is on the negative pressure side of the blower; therefore, air being pulled through the condensate line will prevent positive drainage without a proper trap.

The condensate drain line must be properly trapped, routed to a suitable drain and primed prior to unit commissioning.

NOTE: *Install drain lines and trap so they do not block service access to the unit.*

See Figure 5 for proper drain arrangement. The drain line must pitch to an open drain or pump to prevent clogging of the line. Seal around the drain connection with suitable material to prevent air leakage into the return air system.

To prime trap, pour several quarts of water into drain, enough to fill drain trap and line.

CAUTION

Drain lines should be hand-tightened only. Do not use tools to tighten fitting into drain.

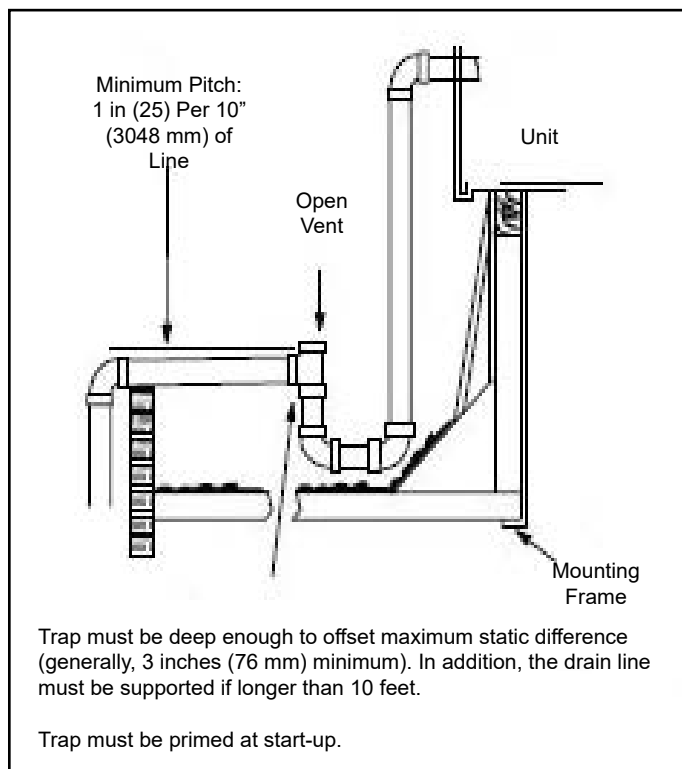

Figure 5. Typical Condensate Drain Connection

Crankcase Heater (if used)

Some models may be equipped with a crankcase heater to prevent excessive migration of liquid refrigerant into the compressor during off cycles. Power must be maintained to the unit to keep this feature active.

Except as required for safety while servicing, **do not open the system disconnect switch.**

Heater Kit Accessory (if used)

The unit is fully equipped for cooling operation without auxiliary heat. A heater kit accessory may also be used. To install the heater kit accessory (see Figure 6):

1. Disconnect the power and open the main control access.
2. Disconnect the plug separating the high voltage wire harness. Remove the high voltage wire harness plug and discard.
3. Remove the heater blockoff by removing the four screws holding it in place.
4. Insert the heater into the control panel and fasten in the same mounting holes.
5. Plug the heater wiring harness into the wire harness on the control assembly. Field wiring of the auxiliary heater is separate from the unit power supply. Wire the power supply wiring for the heater to the appropriate connections on the heater kit.

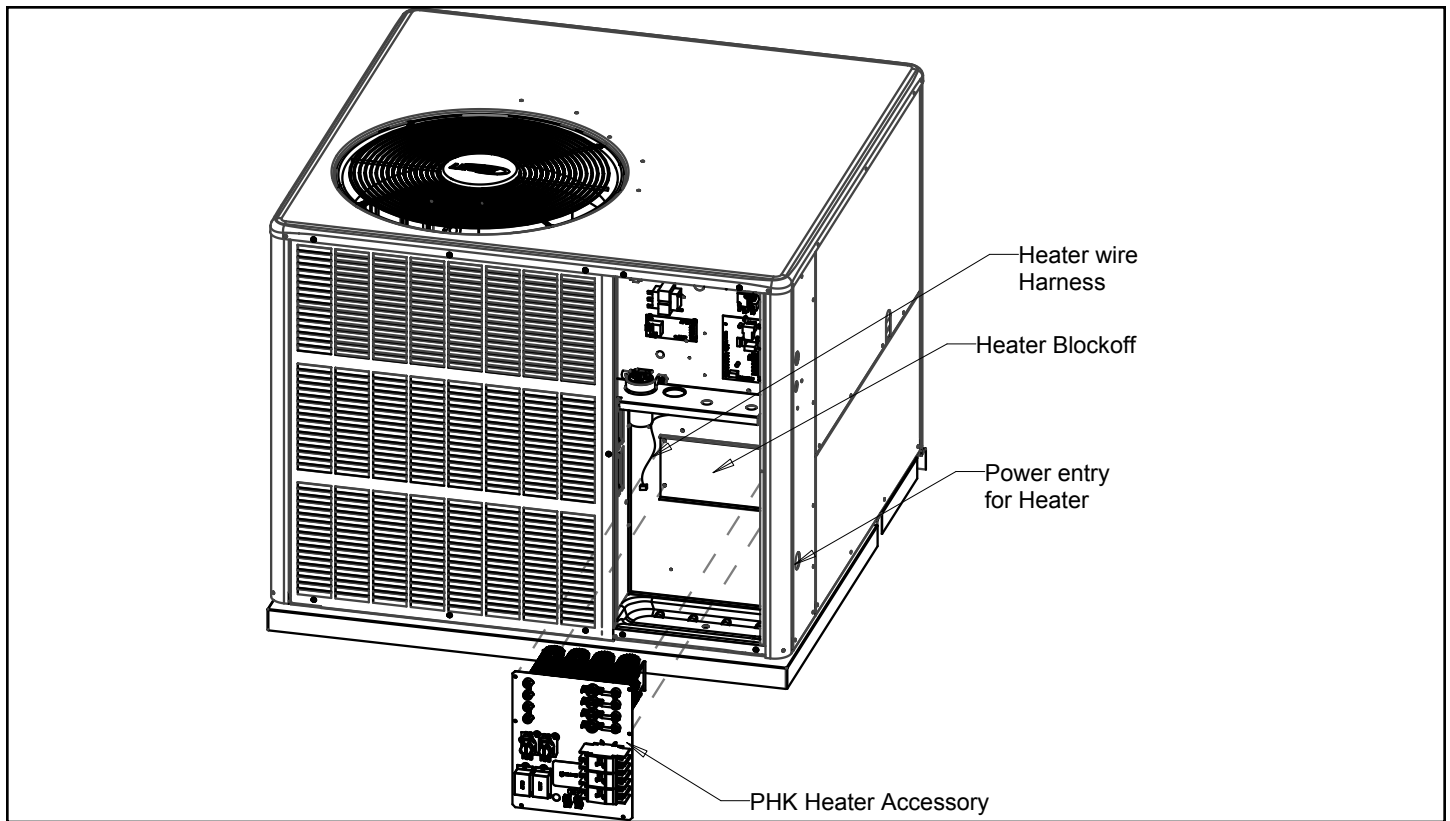

Figure 6. Heater Kit Accessory Installation

Sequence of Operation

Cooling

When the thermostat is in the cooling mode, the O circuit is powered, which energizes the reversing valve. Upon cooling demand, the thermostat closes circuit R and Y. Closing R and Y closes the unit contactor, starting the compressor and outdoor fan. The thermostat automatically closes the R to G circuit, which brings on the indoor blower at the same time. Upon satisfying cooling demand, the thermostat will open the above circuits and open the main contactor, stopping the compressor and outdoor fan. If the unit is equipped with a delay timer, the blower will continue to operate for 60 to 90 seconds, which improves system efficiency.

Heating - Heat Pump Stage

Upon heating demand, the thermostat closes circuit R to Y, which closes the unit contactor, starting the compressor and outdoor fan. The reversing valve is not energized in the heating mode. The thermostat again automatically brings on the indoor fan at the same time. Upon satisfying heating demand, the thermostat opens above circuits and stops unit operation.

Heating - Auxiliary Electric Heat

Upon heating demand for auxiliary electric heat, the thermostat closes circuit R to W, which energizes the heater sequencers as well as the indoor blower. Upon satisfying auxiliary heat demand, the thermostat opens

above circuits and heating elements sequence off; blower continues to operate until all heating elements have turned off.

Defrost System for 2-ton Heat Pumps Demand Defrost System

The demand defrost system measures differential temperatures to detect when the system is performing poorly because of ice build-up on the outdoor coil. The system “self-calibrates” when the defrost system starts and after each system defrost cycle. The demand defrost components on the control board are listed below.

NOTE: *The demand defrost system accurately measures the performance of the system as frost accumulates on the outdoor coil. This typically will translate into longer running time between defrost cycles as more frost accumulates on the outdoor coil before the board initiates defrost cycles.*

Defrost System Sensors

Sensors connect to the defrost board through a field-replaceable harness assembly that plugs into the board. Through the sensors, the board detects outdoor ambient and coil fault conditions. As the detected temperature changes, the resistance across the sensor changes. Sensor resistance values can be checked by ohming across pins.

NOTE: *When checking the ohms across a sensor, be aware that a sensor showing a resistance value that is not*

within the range shown, may be performing as designed. However, if a shorted or open circuit is detected, then the sensor may be faulty and the sensor harness will need to be replaced.

Sensor	Temperature Range °F (°C)	Red LED (DS1)	Pins / Wire Color
Outdoor (ambient)	-35 (-37) to 120 (48)	280,000 to 3750	3 & 4 (black)
Coil	-35 (-37) to 120 (48)	280,000 to 3750	5 & 6 (brown)

NOTE: Sensor resistance decreases as sensed temperature increases.

Table 3. Sensor Temp. / Resistance Range

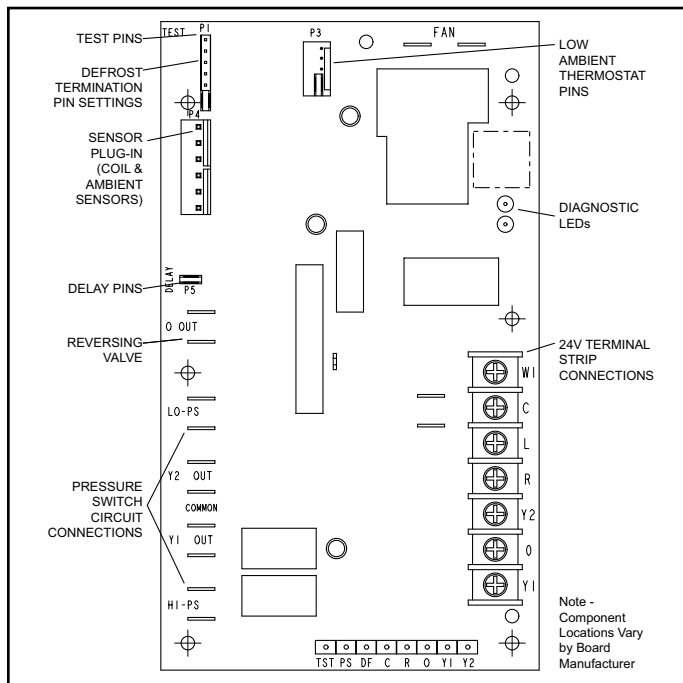

Figure 7. Defrost Control Board (2-Ton Units)

Coil Sensor

The coil temperature sensor considers outdoor temperatures below -35°F (-37°C) or above 120°F (48°C) as a fault. If the coil temperature sensor is detected as being open, shorted or out of the temperature range of the sensor, the board will not perform demand or time/temperature defrost operation and will display the appropriate fault code. Heating and cooling operation will be allowed in this fault condition.

NOTE: The coil temperature probe is designed with a spring clip to allow mounting to the outside coil tubing. Coil sensor location is important for proper defrost operation.

Ambient Sensor

The ambient sensor considers outdoor temperatures below -35°F (-37°C) or above 120°F (48°C) as a fault. If the ambient sensor is detected as being open, shorted or out

of the temperature range of the sensor, the board will not perform demand defrost operation. The board will revert to time/temperature defrost operation and will display the appropriate fault code. Heating and cooling operation will be allowed in this fault condition.

NOTE: Within a single room thermostat demand, if 5-strikes occur, the board will lockout the unit. Control board 24 volt power “R” must be cycled “OFF” or the “TEST” pins on board must be shorted between 1 to 2 seconds to reset the board.

Defrost Temperature Termination Shunt (Jumper) Pins

The defrost board selections are: 50, 70, 90, and 100°F (10, 21, 32 and 38°C). The shunt termination pin is factory set at 50°F (10°C). If the temperature shunt is not installed, the default termination temperature is 90°F (32°C).

Delay Mode

The defrost system has a field-selectable function to reduce occasional sounds that may occur while the unit is cycling in and out of the defrost mode. When a jumper is installed on the DELAY pins, the compressor will be cycled off for 30 seconds going in and out of the defrost mode. Units are shipped with jumper installed on DELAY pins.

NOTE: The 30 second compressor delay feature (known as the quiet shift) **must** be deactivated during any unit performance testing. The feature is deactivated by removing the jumper located on the compressor delay pins on the control board mounted inside the unit control box. This feature is optional for the homeowner, but may impact testing performance.

Defrost Operation

The defrost control system has three basic operational modes: normal, calibration, and defrost.

- **Normal Mode**—The demand defrost system monitors the O line, to determine the system operating mode (heat/cool), outdoor ambient temperature, coil temperature (outdoor coil) and compressor run time to determine when a defrost cycle is required.
- **Calibration Mode**—The board is considered uncalibrated when power is applied to the board, after cool mode operation, or if the coil temperature exceeds the termination temperature when it is in heat mode. Calibration of the board occurs after a defrost cycle to ensure that there is no ice on the coil. During calibration, the temperature of both the coil and the ambient sensor are measured to establish the temperature differential which is required to allow a defrost cycle.
- **Defrost Mode**—The following paragraphs provide a detailed description of the defrost system operation.

Defrost Cycles

The control board initiates a defrost cycle based on either frost detection or time.

- **Frost Detection**—If the compressor runs longer than 30 minutes and the actual difference between the clear coil and frosted coil temperatures exceeds the maximum difference allowed by the control, a defrost cycle will be initiated.

IMPORTANT - The control board will allow a greater accumulation of frost and will initiate fewer defrost cycles than a time/temperature defrost system.

- **Time**—If 6 hours of heating mode compressor run time has elapsed since the last defrost cycle while the coil temperature remains below 35°F (2°C), the control board will initiate a defrost cycle.

Actuation

When the reversing valve is de-energized, the Y1 circuit is energized, and the coil temperature is below 35°F (2°C), the board logs the compressor run time. If the board is not calibrated, a defrost cycle will be initiated after 30 minutes of heating mode compressor run time. The control will attempt to self-calibrate after this (and all other) defrost cycle(s).

Calibration success depends on stable system temperatures during the 20-minute calibration period. If the board fails to calibrate, another defrost cycle will be initiated after 45 minutes of heating mode compressor run time. Once the control board is calibrated, it initiates a demand defrost cycle when the difference between the clear coil and frosted coil temperatures exceeds the maximum difference allowed by the control OR after 6 hours of heating mode compressor run time has been logged since the last defrost cycle.

NOTE: If ambient or coil fault is detected, the board will not execute the "TEST" mode.

Termination

The defrost cycle ends when the coil temperature exceeds the termination temperature or after 14 minutes of defrost operation. If the defrost is terminated by the 14-minute timer, another defrost cycle will be initiated after 30 minutes of run time.

Defrost System for 2.5 - 5-ton Heat Pumps

The defrost system includes two components: the defrost thermostat and the defrost control.

Defrost Thermostat

The defrost thermostat is located on the evaporator coil. When the defrost thermostat senses 35°F or cooler, the thermostat contacts close and send a signal to the defrost control board to start the defrost timing. It also terminates defrost when the liquid line warms up to 60°F.

Defrost Control

The defrost control board includes the combined functions of time/temperature defrost control, defrost relay, diagnostic LEDs and terminal strip for field wiring connections (see Figure 8).

The control provides automatic switching from normal heating operation to defrost mode and back. During the compressor cycle (call for defrost), the control accumulates compressor run time at 30, 60, 90 minute field-adjustable intervals. If the defrost thermostat is closed when the selected compressor run time interval ends, the defrost relay is energized and the defrost begins.

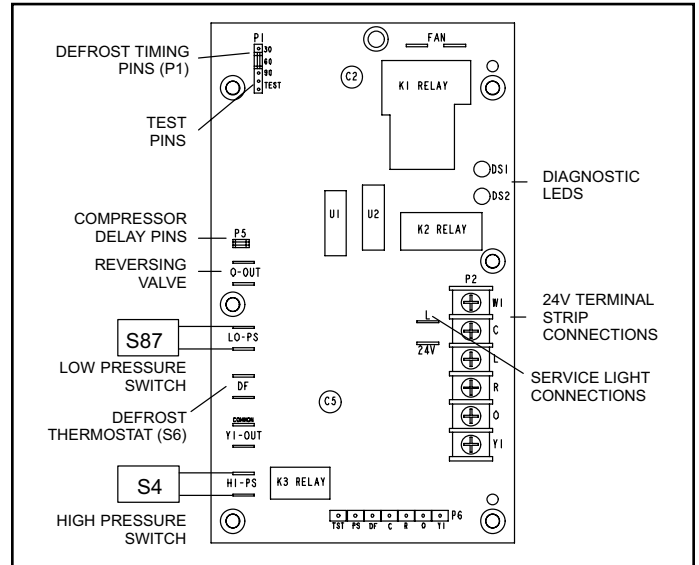

**Figure 8. Defrost Control Board
(2.5 - 5-Ton Units)**

1. An on-board outdoor ambient temperature sensor on the defrost control bypasses the low pressure switch during low ambient temperature below 15°F in heating mode to eliminate nuisance low pressure trips.

NOTE: 15°F is an approximate temperature, depending upon model and installation location.

2. A defrost cycle will initiate when there has been a low pressure switch trip; the defrost sensor must be closed and the defrost time interval must not have expired.
3. At the end of the defrost cycle, when the unit goes back to heating mode, the low pressure switch is checked to see if it has reset. If so, the strikeout is not counted. This prevents lockout during extreme winter conditions.

Defrost Control Timing Pins

Each timing pin selection provides a different accumulated compressor run time period during one thermostat run cycle. This time period must occur before a defrost cycle is initiated. The defrost interval can be adjusted to 30 (T1), 60 (T2), or 90 (T3) minutes. **It is intended that this product should be set at the 60-minute time interval at initial installation.** If the timing selector jumper is not in

place, the control defaults to a 90-minute defrost interval. The maximum defrost period is 14 minutes and cannot be adjusted.

NOTE:

For geographic areas that experience low temperature and high humidity conditions (below 35°F and above 80% RH), the defrost timer pin must be field set at installation to a 60 or 30 minute defrost interval to ensure reliable system operation while in heating mode.

A test option is provided for troubleshooting. The test mode may be started any time the unit is in the heating mode and the defrost thermostat is closed or jumpered. If the jumper is in the TEST position at power up, the control will ignore the test pins. When the jumper is placed across the TEST pins for 2 seconds, the control will enter the defrost mode. If the jumper is removed before an additional 5-second period has elapsed (7 seconds total), the unit will remain in defrost mode until the defrost thermostat opens or 14 minutes have passed. If the jumper is not removed until after the additional 5-second period has elapsed, the defrost will terminate and the test option will not function again until the jumper is removed and reapplied.

Compressor Delay (Quiet Shift)

The defrost board has a field-selectable function to reduce occasional sounds that may occur while the unit is cycling in and out of the defrost mode. The compressor will be cycled off for 30 seconds going in and out of the defrost mode when the compressor delay jumper is removed.

NOTE: *The 30-second “off” cycle is not functional when jumpering the TEST pins.*

Time Delay

The defrost control includes a compressor timer, which ensures the compressor is off for a minimum amount of time between operating cycles.

The timed-off delay is 5 minutes long. The delay helps to protect the compressor from short cycling in case the power to the unit is interrupted or a pressure switch opens. The delay is bypassed by placing the timer select jumper across the TEST pins for 0.5 seconds.

Pressure Switch Circuit

High and low pressure switches are connected to the defrost control board on heat pump models. Air conditioning models have a high pressure switch installed in line with compressor contactor coil (see Figure 8).

During a single demand cycle, the defrost control will lock out the unit after the fifth time that the circuit is interrupted by any pressure switch wired to the control board. In addition, the diagnostic LEDs will indicate a locked-out pressure switch after the fifth occurrence of an open pressure switch (see Table 4).

The unit will remain locked out until power to the board is interrupted, then re-established, or until the jumper is applied to the TEST pins for 0.5 seconds.

NOTE: *The defrost control board ignores input from the low pressure switch terminals as follows:*

- During the TEST mode
- During the defrost cycle
- During the 90-second start-up period
- For the first 90 seconds each time the reversing valve switches heat/cool modes

If the TEST pins are jumpered and the 5-minute delay is being bypassed, the LO PS terminal signal is not ignored during the 90-second start-up period.

5-Strike Lockout Feature

The internal control logic of the board counts the pressure switch trips only while the Y1 (Input) line is active. If a pressure switch opens and closes four times during a Y1 (Input), the control logic will reset the pressure switch trip counter to zero at the end of the Y1 (Input). If the pressure switch opens for a fifth time during the current Y1 (Input), the control will enter a lockout condition.

The 5-strike pressure switch lockout condition can be reset by cycling OFF the 24-volt power to the control board or by shorting the TEST pins between 1 and 2 seconds. All timer functions (run times) will also be reset.

If a pressure switch opens while the Y1 Out line is engaged, a 5-minute short cycle will occur after the switch closes.

Diagnostic LEDs

The defrost board uses two LEDs for diagnostics. The LEDs flash a specific sequence according to the condition as shown in Table 4.

Defrost Board Diagnostic LEDs		
Green LED (DS2)	Red LED (DS1)	Condition
OFF	OFF	No Power to Control
Simultaneous slow FLASH		Normal Operation / Power to Control
Alternating Slow FLASH		5-min Anti-Short-Cycle Delay
ON	Slow FLASH	Low Pressure Switch Ignored (Low Ambient)
Fault & Lockout Codes		
OFF	Slow FLASH	Low Pressure Switch Fault
OFF	ON	Low Pressure Switch Lockout
Slow FLASH	OFF	High Pressure Switch Fault
ON	OFF	High Pressure Switch Lockout

Table 4. Defrost Control (CMC1) Diagnostic LEDs

System Performance

This equipment is a self-contained, factory optimized refrigerant system, and should not require adjustments to system charge when properly installed. If unit performance is questioned, perform the following checks.

Ensure unit is installed per manufacturer's instructions and that line voltage and air flow is correct. Refer to the following tables for proper performance value. The indoor metering device varies by model; when checking performance of a unit using an orifice for metering, refer to the suction superheat value to judge performance. When checking performance of a unit that uses an expansion valve for metering, refer to the subcooling value to judge system performance.

If the measured performance value varies from table value allowance, check internal seals, service panels and duct work for air leaks, as well as restrictions and blower speed settings. If unit performance remains questionable, remove system charge, evacuate to 500 microns, and weigh in refrigerant to nameplate charge. It is critical that the exact charge is re-installed. Failure to comply will compromise system performance.

If unit performance is still questionable, check for refrigerant related problems, such as blocked coil or circuits, malfunctioning metering device or other system components.

Model	Suction Superheat +/- 3°	Liquid Subcooling +/- 2°
2 Ton	13	
2.5 Ton	15	
3 Ton	15	
3.5 Ton	13	
4 Ton	14	
5 Ton	16	

Based on outdoor ambient temperature of 82°F, and indoor entering air of 80°F db, 67°F wb.

Table 5. Air Conditioner Unit Cooling System Performance Values

Model	Suction Superheat +/- 3°	Liquid Subcooling +/- 2°
2 Ton	17	
2.5 Ton	15	
3 Ton		8
3.5 Ton	17	
4 Ton	17	
5 Ton		11

Based on outdoor ambient temperature of 82°F, and indoor entering air of 80°F db, 67°F wb.

Table 6. Heat Pump Cooling System Performance Values

Model	Liquid Subcooling +/- 2°
2 Ton	27
2.5 Ton	10
3 Ton	11
3.5 Ton	34
4 Ton	39
5 Ton	46

Based on outdoor ambient temperature of 47°F, and indoor entering air of 70°F db.

Table 7. Heat Pump Heating System Performance Values

Maintenance

WARNING

Before performing maintenance operations on the system, shut off all electrical power to the unit. Turn off accessory heater power switch if applicable. Electrical shock could cause personal injury or death.

Periodic inspection and maintenance normally consists of changing or cleaning the filters and cleaning the evaporator coil. On occasion, other components may also require cleaning.

Filters

Filters are not supplied with the unit. Inspect once a month. Replace disposable or clean permanent type as necessary. Do not replace permanent type with disposable.

Motors

Indoor and outdoor fan and vent motors are permanently lubricated and require no maintenance.

Indoor fans are equipped with a permanent magnet constant torque motor. These motors remain energized and are controlled by 24V signals. For high static applications, use Tap 3 for cooling speed and Tap 5 for heating speed.

Evaporator Coil

Dirt and debris should not be allowed to accumulate on the evaporator coil surface or other parts in the air circuit. Cleaning should be as often as necessary to keep coil clean. Use a brush, vacuum cleaner attachment, or other suitable means. If water is used to clean the coil, be sure the power to unit is shut off prior to cleaning. **Care should be used when cleaning the coil so that the coil fins are not damaged.**

Do not permit the hot condenser air discharge to be obstructed by overhanging structures or shrubs.

Condenser Coil

Clean condenser coil annually with water and inspect monthly during the cooling season.

Condenser coil may need to be cleaned at startup in case oil from the manufacturing process is found on the condenser coil.

Table 8. Cooling Performance - AC Models

80 DB / 67 WB Deg. Return Air		Air Temperature Entering Evaporator Coil, Degree F										
Cooling Input (1000 BTU)	Pressure	65°	70°	75°	80°	85°	90°	95°	100°	105°	110°	115°
24	Suction	135	135	135	136	137	140	143	147	151	157	163
30		135	137	139	141	144	146	149	151	154	157	160
36		136	138	139	141	143	145	147	149	151	154	156
42		137	137	136	137	138	140	142	145	149	154	159
48		138	138	139	140	141	142	144	147	150	153	157
60		130	132	133	135	137	139	140	143	145	147	149
24	Liquid	233	250	268	287	307	329	352	377	402	429	458
30		242	259	278	298	319	341	364	390	416	443	472
36		257	275	294	315	337	361	387	412	440	469	499
42		250	269	288	308	330	353	377	402	429	456	485
48		268	285	304	325	347	370	398	422	451	481	512
60		250	268	287	308	330	353	378	404	431	460	490

Table 10. Cooling Performance - HP Models

80 DB / 67 WB Deg. Return Air		Air Temperature Entering Evaporator Coil, Degree F										
Cooling Input (1000 BTU)	Pressure	65°	70°	75°	80°	85°	90°	95°	100°	105°	110°	115°
24	Suction	139	141	143	145	147	150	152	155	157	160	163
30		136	138	140	142	145	147	151	153	155	159	162
36		142	142	142	143	143	145	145	148	150	153	155
42		141	141	141	142	143	145	146	151	155	159	164
48		138	139	140	142	143	145	147	151	154	157	161
60		136	136	136	136	137	138	139	141	143	146	148
24	Liquid	234	255	277	299	322	345	370	393	417	442	467
30		253	272	293	314	337	360	385	411	438	465	494
36		245	269	292	316	340	364	390	414	438	464	489
42		241	259	279	300	322	346	369	395	421	448	477
48		263	279	296	316	338	362	384	415	445	477	511
60		257	272	289	308	330	354	383	408	438	470	505

Table 9. Heating Performance - HP Models

70 Deg. F Return Air		Air Temperature Entering Evaporator Coil, Degree F											
Cooling Input (1000 BTU)	Pressure	0°	5°	10°	17°	20°	25°	35°	40°	47°	50°	55°	60°
24	Suction	36	41	47	56	60	67	82	91	104	110	120	130
30		34	39	45	53	57	64	79	87	99	104	113	123
36		18	28	37	49	54	63	80	88	101	103	111	118
42		30	37	44	53	58	65	81	89	104	106	115	125
48		38	43	49	57	61	68	82	90	101	108	117	127
60		28	34	40	50	54	61	77	84	95	101	110	119
24	Liquid	297	290	286	286	287	293	313	328	346	368	393	421
30		276	269	265	262	262	264	275	284	302	309	325	343
36		279	275	274	275	276	281	295	305	324	331	347	364
42		344	330	319	311	310	312	327	340	365	378	404	433
48		392	368	350	333	330	328	340	354	375	399	429	465
60		356	357	360	367	372	380	403	417	426	451	471	493

DIAGNOSTIC CODES FOR DEFROST CONTROL LEDS

(See instructions or markings on System Diagnostic Module for codes of System Diagnostic Module)

Description	DSI (GREEN)	DS2 (RED)
No Power to Control	OFF	OFF
Normal Operation / Power to Control	Simultaneous Slow Flash	Simultaneous Slow Flash
Anti-Short Cycle Lockout	Alternate Slow Flash	Alternate Slow Flash
Low Pressure Switch Fault	OFF	Slow Flash
High Pressure Switch Fault	OFF	ON
High Pressure Switch Lockout	ON	OFF

Note: Because the Pressure Switches are monitored only when "Y1" (Demand) is active, the code for pressure switch open will not be seen when "Y1" is off. Instead, the "Normal Operation" or "Anti Short Cycle" code will be seen.

Also, when a pressure switch opens and causes a short cycle lockout, the pressure switch status code will be seen until it closes, then the short cycle lockout code will flash unless it has already expired.

CONNECTION DIAGRAM, HEAT PUMP CONSTANT TORQUE BLOWER, SINGLE PHASE

NOTE: TAP 1 FOR FAN ONLY
TAP 2 FOR FAN & HEATING COOLING
TAP 3 FOR FAN & HEATING COOLING
TAP 4 AND TAPS FOR ELECTRIC HEAT - REFER TO HEATING LABEL

NOTE: IF ANY OF THE ORIGINAL WIRE IS REPLACED THE SAME SIZE AND TYPE WIRE MUST BE USED.
USE COPPER CONDUCTOR ONLY, MIN 15°C WIRE

INDOOR BLOWER MOTOR

W1 & W2 CAN BE USED TO STAGE ELECTRIC HEAT ACCESSORY ON 10, 15 & 20KW MODELS
5.8-7.5 KW HEATER ACCESSORIES FUNCTION OFF W/ ONLY.

J1: PLUG THROUGH CONTROL PANEL (12 PIN)
J2: PLUG FOR ACCESSORY HEAT (6 PIN)

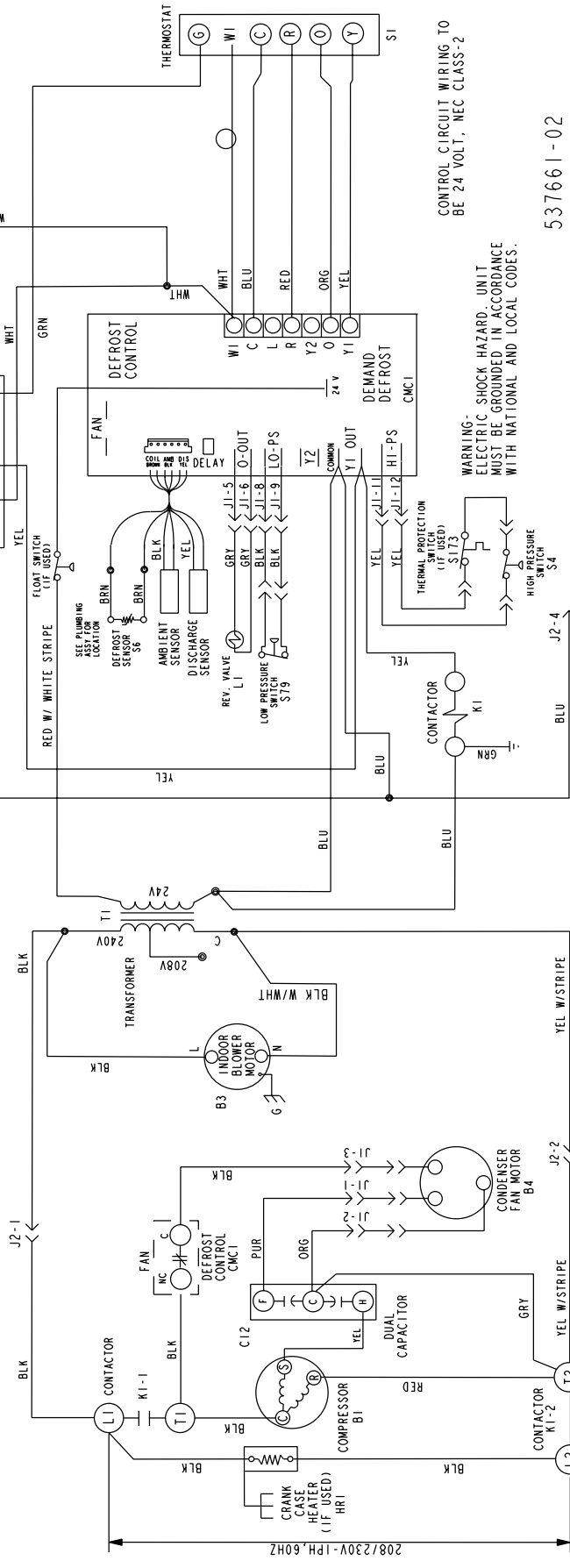

CONTROL CIRCUIT WIRING TO BE 24 VOLT, NEC CLASS-2

WARNING - ELECTRIC SHOCK HAZARD. UNIT MUST BE GROUNDED IN ACCORDANCE WITH NATIONAL AND LOCAL CODES.

537661-02

LINE VOLTAGE FIELD INSTALLED

Figure 10. Connections Diagram - Heat Pump Constant Torque (2-ton)

DIAGNOSTIC CODES FOR DEFROST CONTROL LEDS

(See instructions or markings on System Diagnostic Module for codes of System Diagnostic Module)

Description	DS1 (GREEN)	DS2 (RED)
No Power to Control	OFF	OFF
Normal Operation / Power to Control	Simultaneous Slow Flash	
Anti-Short Cycle Lockout	Alternate Slow Flash	
Low Pressure Switch Fault	OFF	Slow Flash
High Pressure Switch Fault	OFF	ON
High Pressure Switch Lockout	ON	OFF
High Pressure Switch Lockout	ON	OFF

CONNECTION DIAGRAM, HEAT PUMP CONSTANT TORQUE BLOWER, SINGLE PHASE

NOTE: TAP1 FOR FAN ONLY
TAP 2 FOR COOLING
TAP3 FOR HIGH STATIC COOLING
TAP4 AND TAP5 FOR ELECTRIC HEAT - REFER TO HEATING LABEL

NOTE: IF ANY OF THE ORIGINAL WIRE IS REPLACED THE SAME SIZE AND TYPE WIRE MUST BE USED. USE COPPER CONDUCTOR ONLY. MIN 75°C WIRE

Note: Because the Pressure Switches are monitored only when "Y1" (Inop) is active, the code for pressure switch open will not be seen when "Y1" is off. Instead, the "Normal Operation" or "Anti Short Cycle" code will be seen.
Also, when a pressure switch opens and causes a short cycle lockout, the pressure switch-open code will be seen until it closes, then the short cycle lockout code will flash unless it has already expired.

J1: PLUG THROUGH CONTROL PANEL (12 PIN)
J2: PLUG FOR ACCESSORY HEAT (6 PIN)

INDOOR BLOWER MOTOR
W1 & W2 CAN BE USED TO STAGE ELECTRIC HEAT ACCESSORY ON 10, 15 & 20KW MODELS
5.8-7.5 KW HEATER ACCESSORIES FUNCTION OFF W1 ONLY.

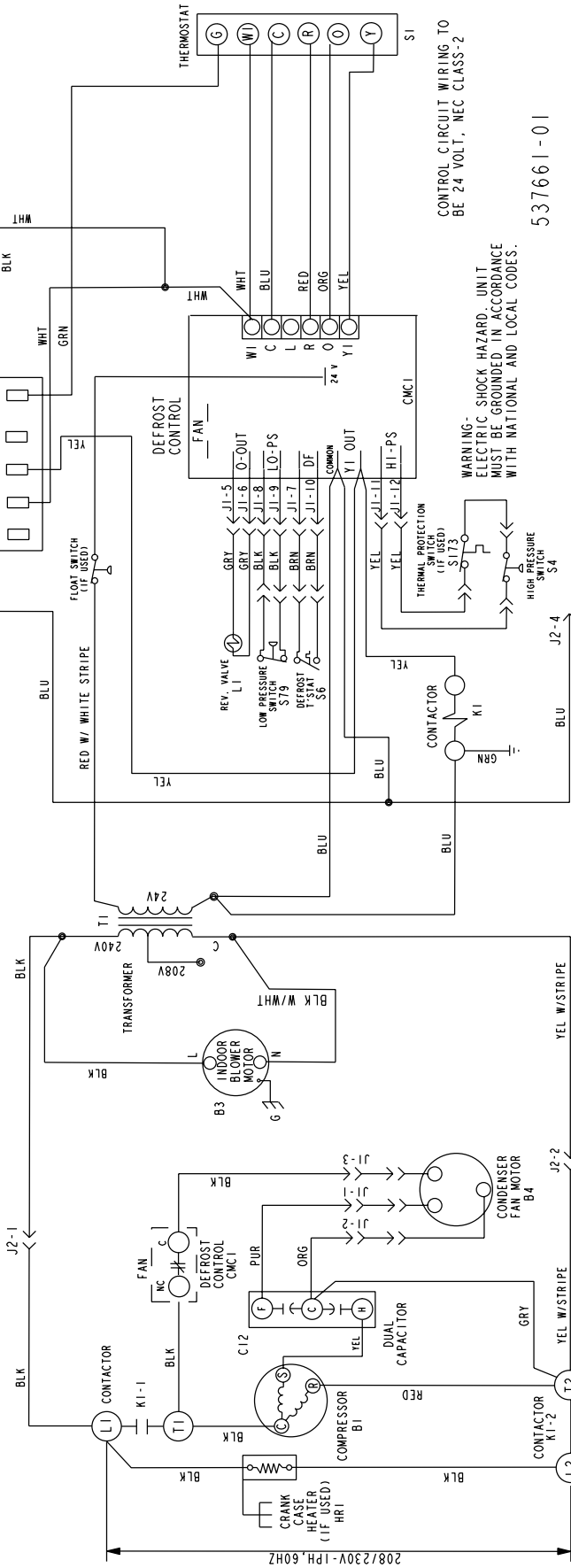

CONTROL CIRCUIT WIRING TO BE 24 VOLT, NEC CLASS-2

537661-01

WARNING: ELECTRIC SHOCK HAZARD. UNIT MUST BE GROUNDED IN ACCORDANCE WITH NATIONAL AND LOCAL CODES.

LINE VOLTAGE FIELD INSTALLED

Figure 11. Connections Diagram - Heat Pump Constant Torque (2.5 - 5-ton)